

Publication number : 05-036426

Date of publication of application : 12.02.1993

Int.Cl. H01M 8/02 H01M 8/12

5

Application number : 03-213059

Applicant : MITSUBISHI HEAVY IND LTD

Date of filing : 31.07.1991

Inventor :

10 TSUKUDA HIROSHI

SOLID ELECTROLYTIC FUEL CELL

15 [Abstract]

PURPOSE: To prevent the crack of a solid electrolyte by a thermal distortion by using a seal material in which a specified volume of SnO₂ particles having a specified particle size are added to a glass having specified values of thermal expansion coefficient and melting point.

20 **CONSTITUTION:** A seal member 6 is applied to the connecting part between a solid electrolyte 1 and a ceramic tube 3 of different member in a solid electrolytic fuel cell, and the both are sealed and fixed to each other. When a seal member in which 5-40% by volume of SnO₂ particles having a particle size of 10-500µm are added to a glass having a melting point of

800 to 110°C is used as the member 6, the cracking of the solid electrolyte caused by a thermal distortion is prevented.

[CLAIMS]

[Claim(s)]

[Claim 1] A solid electrolyte fuel cell characterized in that a seal member 6
5 in which 5 to 40% by volume of SnO₂ particles having a particle size of 10
to 500μm are added to a glass having a thermal expansion coefficient
more than $2 \times 10^{-6}/^{\circ}\text{C}$ higher than that of SnO₂ particles and a melting point
of 800 to 110°C, is applied to the connecting part between a solid
electrolyte and a different member and the connecting part is sealed and
10 fixed.

DETAILED DESCRIPTION

[Title of the invention]

SOLID ELECTROLYTIC FUEL CELL

[Detailed Description of the Invention]

5 **[0001]**

[Industrial Application] This invention relates to a solid electrolyte fuel cell, and particularly to the sealing of the connecting part between a solid electrolyte and a different members of the solid electrolyte fuel cell.

[0002]

10 **[Description of the Prior Art]** The solid electrolyte fuel cell shown in FIG. 1 consists of an electrolyte 1, porous electrodes 2 which were applied to both sides of an electrolyte 1, a ceramic tube 3 for supporting the electrolyte 1, an electric ejection line 4 for to supply power, which is connected to the electrode 2, a gas pipe 5 for supplying and discharging
15 fuel gas to and from the electrolyte 1, a seal member 6 for sealing the fuel gas in a high-temperature section near the electrolyte 1, the rubber plugs 7 sealing the fuel gas in the low-temperature section, the silicone rubber 8, and electric furnaces 9.

[0003] In the conventional solid electrolyte fuel cell, the thermal expansion
20 coefficient of a seal member is similar to that of the electrolyte 1 and the seal member 6 melts at the temperature near the that of the activation of a solid electrolyte fuel cell .

[0004]

[Problem(s) to be Solved by the Invention] In the conventional solid
25 electrolyte fuel cell, although the thermal expansion coefficient of a seal

member 6 is similar to that of the electrolyte 1, the crack of the electrolyte 1 has occurred at the time of cooling due to the stress generated by the slight difference of a thermal expansion coefficient, for this reason there was a disadvantage that the fuel gas may be leaked when the temperature is raised, so that the output of a fuel cell may be deteriorated.

[0005] An object of the present invention is to solve the above-mentioned problems in view of the above-mentioned technical level and to provide a solid electrolyte fuel cell without the above disadvantages that the conventional solid electrolyte fuel cell has.

10 [0006]

[Means for Solving the Problem] This invention relates to a solid electrolyte fuel cell characterized in that a seal member 6 in which 5 to 40% by volume of SnO₂ particles having a particle size of 10 to 500μm are added to a glass having a thermal expansion coefficient more than 2x10-6/°C higher than that of SnO₂ particles and a melting point of 800 to 110°C, is applied to the connecting part between a solid electrolyte and a different member and the connecting part is sealed and fixed.

[0007] As the solid electrolyte used in this invention, generally ZrO₂ can be used, and as a glass having a thermal expansion coefficient more than 2x10-6/°C higher than that of SnO₂ particles and a melting point of 800 to 110°C, the common glass can be used since it has such a property.

[0008]

[Function] After operating a solid electrolyte fuel cell and raising its temperature up to a high temperature (800 to 1100 °C), when it descends

to a room temperature, difference of thermal expansion coefficients among those of a sealing material matrix (glass), a dispersed particle (SnO_2) and a solid electrolyte causes a distortion among them. If the sealing material in this invention is used, the crack generated by the distortion which occurs in a sealing material can be prevented from making a solid electrolyte generate distortion.

[0009] The reason to add a seal member of this invention are added to a glass having a thermal expansion coefficient more than $2 \times 10^{-6}/^\circ\text{C}$ higher than that of SnO_2 particles (its thermal expansion coefficient: $4 \times 10^{-6}/^\circ\text{C}$) and a melting point of 800 to 10° is to generate a crack in the sealing material and not to generate a crack in the solid electrolyte at the operating temperature (800 to 1100°C) of a solid electrolyte fuel cell. In addition, SnO_2 particles exist in the condition of being dispersed in the glass.

[0010] The sealing material of this invention is not affected under stress by generating a crack in itself so that it prevents generation of the crack in the solid electrolyte. When it is used again, however, a crack is disappeared by being heated and melted so that it can be used as a sealing material again.

[0011] If a sealing material in which SnO_2 with a mean particle diameter of 20 micrometers is added by 10 capacity % in common glass (thermal expansion coefficient: $9.6 \times 10^{-6}/^\circ\text{C}$) is used in this invention as an example of the sealing materials used in this invention, the flexural strength is about 2.8 kgf/cm^2 .

[0012] The photograph of the microstructure of the sealing material of this

invention taken by an optical microscope (magnifications: 500 times) is shown in FIG 1.

[0013]

[Example] The experiment on the sealing material used for the solid electrolyte fuel cell of this invention has performed using PbO-Al₂O₃-SiO₂ glass as a matrix. The experimental result will be described as follows.

[0014] Effect of the thermal expansion coefficient of a sealing material on a solid electrolyte (8mol% Y₂O₃ZrO₂) (Table 1)

The sealing material in which SnO₂ with mean particle diameter of 30 micrometers and thermal expansion coefficient of 4x10⁻⁶/°C is dispersed by 20 capacity % in the sealing material matrix having thermal expansion coefficient of 4x10⁻⁶/°C, 6x10⁻⁶/°C, and 8x10⁻⁶/°C respectively is applied as a sealing material of FIG. 1. After checking the leakage of the sealing at 1000°C, descending a temperature and drawing the solid electrolyte out off the furnace and observed if the crack had occurred or not. Subsequently put it back to the furnace and raise temperature and checke the sealing at 1000°C again. This result is shown in Table 1.

[Table 1]

Thermal expansion coefficient of a sealing material	4x10 ⁻⁶ /°C	6x10 ⁻⁶ /°C	8x10 ⁻⁶ /°C
Thermal expansion coefficient of a sealing material - Thermal expansion coefficient of a dispersed particle	○	2x10 ⁻⁶ /°C	4x10 ⁻⁶ /°C
Sealing at a high temperature	○	○	○

Sealing after descending temperature	Crack was found in the solid electrolyte	Crack was found in the sealing material	Crack was found in the sealing material
Sealing after re-raising temperature	X	o	o
Overall assessment	X	o	o

5 [0015] From the above result, we founded that a crack does not occur in a solid electrolyte when the thermal expansion coefficient of a sealing material matrix is large, and a difference of the thermal expansion coefficient of the sealing material matrix and a dispersed particle material is more than $2 \times 10^{-6}/^{\circ}\text{C}$.

[0016] Effect of the diameter of the particles dispersed in the sealing material with the generation of the crack in a solid electrolyte (Table 2)

10

15 The sealing material in which SnO_2 with mean particle diameter of 5, 10, 30, 250, 500, and 750 micrometers and thermal expansion coefficient of $4 \times 10^{-6}/^{\circ}\text{C}$ is dispersed by 20 capacity % in the sealing material matrix having thermal expansion coefficient of $8 \times 10^{-6}/^{\circ}\text{C}$ respectively is applied as a sealing material of FIG. 1. After checking the leakage of the sealing at

1000°C, the temperature was lowered and the solid electrolyte was drawn out of the furnace and was observed if the crack had occurred or not. Subsequently, the electrolyte was put back into the furnace and temperature was raised before checking the sealing at 1000°C again. This result is shown in Table 2.

[Table 2]

Particle diameter	5	10	30	250	500	750
Sealing at a high temperature	○	○	○	○	○	X
Sealing after descending a temperature	Crack was found in the solid electrolyte	Crack was found in the sealing material	←	←	←	←
Sealing after re-raising a temperature	X	○	○	○	○	X
Overall assessment	X	○	○	○	○	X

10

[0017] The above result shows that a crack does not occur in a solid electrolyte, if the diameter of a particulate material is 10 to 500 micrometers.

[0018] Effect of the amount of the dispersed particle mixed in a sealing

material on the generation of crack in a solid electrolyte (Table 3)

The sealing material in which SnO₂ with mean particle diameter of 30 micrometers and thermal expansion coefficient of 4x10⁻⁶/°C is dispersed by 3, 5, 10, 20, 40, and 60 capacity % in the sealing material matrix having thermal expansion coefficient of 8x10⁻⁶/°C respectively is applied as a sealing material of FIG. 1. After checking the leakage of the sealing at 1000°C, the temperature was lowered and the solid electrolyte was removed from the furnace and was observed if the crack had occurred or not. Subsequently, the electrolyte was put back into the furnace and the temperature was raised before checking the sealing at 1000°C again. This result is shown in Table 2.

[Table 3]

15

amount of the dispersed particle	3	5	10	20	40	60
Sealing at a high temperature	○	○	○	○	○	X
Sealing after descending a temperature	Crack was found in the solid electrolyte	Crack was found in the sealing material	←	←	←	←
Sealing after re-raising a	X	○	○	○	○	X

temperatur e						
Overall assessment	X	o	o	o	o	X

[0019] The above result shows that a crack does not occur in a solid electrolyte, if the amount of dispersed particle is 5 to 40 capacity %.

[0020]

- 5 [Effect of the Invention] This invention provides a solid electrolyte fuel cell which can prevent the generation of a crack in a solid electrolyte caused by the thermal strain that is generated by the difference of thermal expansion coefficients among those of a sealing material, a dispersed particle and a solid electrolyte causes a distortion among them at the time
- 10 of raising and descending temperature.

[Brief Description of the Drawings]

FIG.1 is an explanatory view of a solid electrolyte fuel cell.

- FIG. 2 is an optical microscope photograph in which the detailed
- 15 organization of the sealing material used by this invention is shown.

(19) 日本国特許庁 (JP)

(12) 公開特許公報 (A)

(11) 特許出願公開番号

特開平5-36426

(43) 公開日 平成5年(1993)2月12日

(51) Int.Cl. ⁵	識別記号	庁内整理番号	F I	技術表示箇所
H 0 1 M 8/02	S	9062-4K		
	E	9062-4K		
8/12		9062-4K		

審査請求 未請求 請求項の数1(全4頁)

(21) 出願番号 特願平3-213059

(22) 出願日 平成3年(1991)7月31日

(71) 出願人 000006208

三菱重工業株式会社

東京都千代田区丸の内二丁目5番1号

(72) 発明者 佃 洋

長崎市飽の浦町1番1号 三菱重工業株式会社長崎研究所内

(74) 代理人 弁理士 内田 明 (外2名)

(54) 【発明の名称】 固体電解質燃料電池

(57) 【要約】

【目的】 固体電解質燃料電池に関する。

【構成】 固体電解質と異部材間の接合部に、 SnO_2 熱膨張率より $2 \times 10^{-6} / ^\circ\text{C}$ 以上大きく、かつ $800 \sim 1100^\circ\text{C}$ の融点を有するガラスに、粒径 $10 \sim 500 \mu\text{m}$ の SnO_2 粒子を $5 \sim 40$ 容量% 添加したシール材を塗布して、前記接合部を密封固定してなる固体電解質燃料電池。

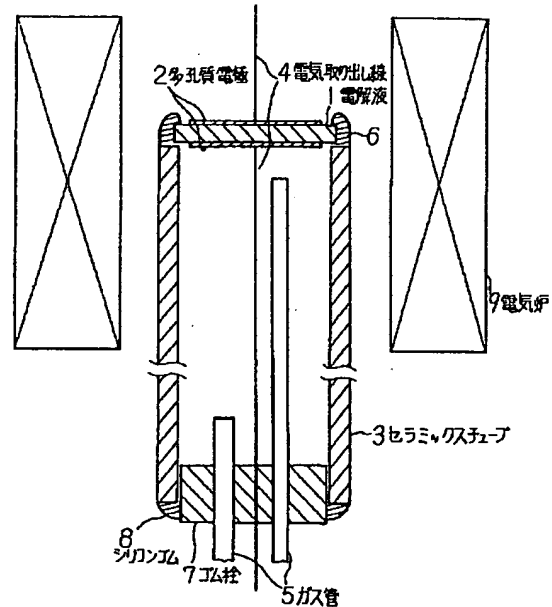

【特許請求の範囲】

【請求項1】 固体電解質と異部材間の接合部に、 SnO_2 熱膨張率より $2 \times 10^{-6}/^\circ\text{C}$ 以上大きく、かつ $800 \sim 1100^\circ\text{C}$ で融けるガラスに、粒径 $10 \sim 500 \mu\text{m}$ の SnO_2 粒子を $5 \sim 40$ 容量%添加したシール材を塗布して、前記接合部を密封固定してなることを特徴とする固体電解質燃料電池。

【発明の詳細な説明】

【0001】

【産業上の利用分野】本発明は固体電解質燃料電池に関し、特に該電池の固体電解質と異部材間の接合部のシールに関する。

【0002】

【従来の技術】図1に示す固体電解質燃料電池は、電解質1、該電解質1の両面に塗布された多孔質電極2、該電解質1を支持するためのセラミックチューブ3、該電極2に接続され、出力を取り出すための電気取り出し線4、前記電解質1に燃料ガスを供給、排出するためのガス管5、前記電解質1近傍の高温部での燃料ガスのシールを行うためのシール材6、低温部での燃料ガスのシールを行うためのゴム栓7、シリコンゴム8及び電気炉9より構成されている。

【0003】従来の固体電解質燃料電池においては、シール材6は電解質1に熱膨張率が近く、固体電解質燃料電池の作動付近の温度で溶融する。

【0004】

【発明が解決しようとする課題】従来の固体電解質燃料電池では、シール材6と電解質1の熱膨張率を近くしているが、僅かな熱膨張率の差で発生する応力のため冷却時に電解質1が割れ、このため再度高温にした場合、燃料ガスがもれ、燃料電池の出力が低下する欠点があった。

【0005】本発明は上記技術水準に鑑み、従来の固体電解質燃料電池の有する上述のような欠点のない固体電解質燃料電池を提供しようとするものである。

【0006】

【課題を解決するための手段】本発明は固体電解質と異部材間の接合部に、 SnO_2 熱膨張率より $2 \times 10^{-6}/^\circ\text{C}$ 以上大きく、かつ $800 \sim 1100^\circ\text{C}$ で融けるガラスに、粒径 $10 \sim 500 \mu\text{m}$ の SnO_2 粒子を $5 \sim 40$ 容量%添加したシール材を塗布して、前記接合部を密封固定してなることを特徴とする固体電解質燃料電池である。

【0007】本発明で使用される固体電解質としては一般的に ZrO_2 系のものが使用され、また、 SnO_2 の熱膨張率より $2 \times 10^{-6}/^\circ\text{C}$ 以上大きく、かつ $800 \sim 1100^\circ\text{C}$ の融点を有するガラスとしては一般的なガラ

スがこの物性を有するので、殆どどのガラスが使用できる。

【0008】

【作用】固体電解質燃料電池を作動させ、高温($800 \sim 1100^\circ\text{C}$)にした後、温度を室温まで降下した時、シール材マトリックス(ガラス)と分散粒子(SnO_2)、固体電解質の間に熱膨張率差が生じ歪が発生する。本発明におけるシール材を使用すると、この歪により発生する割れがシール材の内部で発生し、固体電解質に歪を発生させないようにすることができる。

【0009】本発明におけるシール材を、 SnO_2 (熱膨張率： $4 \times 10^{-6}/^\circ\text{C}$)の熱膨張率より $2 \times 10^{-6}/^\circ\text{C}$ 以上大きく、かつ $800 \sim 1100^\circ\text{C}$ で融けるガラスに、粒径 $10 \sim 500 \mu\text{m}$ の SnO_2 粒子を $5 \sim 40$ 容量%添加したものにするのは、固体電解質燃料電池の作動温度($800 \sim 1100^\circ\text{C}$)で、該シール材に割れを発生させ、固体電解質に割れの発生を起させないためである。なお、 SnO_2 粒子はガラス中に分散した状態で存在する。

【0010】本発明におけるシール材はそれ自体が割れることによって応力を逃がし、固体電解質の割れを防止するが、次に使用する時には加熱して融けることにより割れがなくなり、再びシール材として機能する。

【0011】本発明におけるシール材の一例として、一般のガラス(熱膨張率： $9.6 \times 10^{-6}/^\circ\text{C}$)に平均粒径 $20 \mu\text{m}$ の SnO_2 粒子を 10 容量%添加したものを例に採ると、その曲げ強度は約 $2.8 \text{ kgf}/\text{cm}^2$ である。

【0012】本発明におけるシール材の微細組織の光学顕微鏡写真(倍率： 500 倍)を図2に示す。

【0013】

【実施例】本発明の固体電解質燃料電池に使用するシール材について、マトリックスとして $\text{PbO}-\text{Al}_2\text{O}_3-\text{SiO}_2$ ガラスを用い、下記の諸点についての実験結果を説明する。

【0014】① シール材の熱膨張率が固体電解質($8 \text{ mol}\% \text{ Y}_2\text{O}_3-\text{ZrO}_2$)に与える影響(表1) 熱膨張率が $4 \times 10^{-6}/^\circ\text{C}$ の平均粒径 $30 \mu\text{m}$ の SnO_2 を、熱膨張率が $4 \times 10^{-6}/^\circ\text{C}$ 、 $6 \times 10^{-6}/^\circ\text{C}$ 、 $8 \times 10^{-6}/^\circ\text{C}$ のシール材マトリックス中に 20 容量%分散させたシール材を図1のシール材6に適用した。 1000°C でのシールの漏れを確認した後、降温後の割れ状況を降温後炉外に固体電解質部を取出し観察し、次いで固体電解質部を炉内に入れて再昇温し、 1000°C でのシール状況を再度確認した。この結果を表1に示す。

【表1】

3

4

シール材の熱膨張率	$4 \times 10^{-6} / ^\circ\text{C}$	$6 \times 10^{-6} / ^\circ\text{C}$	$8 \times 10^{-6} / ^\circ\text{C}$
シールの熱膨張率- 分散粒子の熱膨張率	○	$2 \times 10^{-6} / ^\circ\text{C}$	$4 \times 10^{-6} / ^\circ\text{C}$
高温でのシール状況	○	○	○
降温後の状況	固体電解質に割 れ	シール材中に割 れ	シール材中に割 れ
再昇温後のシール状 況	×	○	○
総合判断	×	○	○

【0015】以上の結果より、シール材マトリックスの熱膨張率の方が大きく、分散粒子の熱膨張率との差が $2 \times 10^{-6} / ^\circ\text{C}$ 以上であれば固体電解質に割れが発生しないことが判る。

【0016】② シール材に分散する分散粒子の粒径が固体電解質の割れに与える影響 (表2)

熱膨張率が $8 \times 10^{-6} / ^\circ\text{C}$ のシール材マトリックス中*

*に、熱膨張率が $4 \times 10^{-6} / ^\circ\text{C}$ の SnO_2 で、平均粒径が $5 \mu\text{m}$ 、 $10 \mu\text{m}$ 、 $30 \mu\text{m}$ 、 $250 \mu\text{m}$ 、 $500 \mu\text{m}$ 、 $750 \mu\text{m}$ のものを20容量%分散させ、これらの
2) シール材を図1のシール材6に適用した。次に、上記①と同様な確認試験を行い、その結果を表2に示す。

【表2】

分散粒子径	5	10	30	250	500	750
高温でのシール状況	○	○	○	○	○	×
降温後の状況	固体電 解質に 割れ	シール 材中に 割れ	←	←	←	←
再昇温後のシール状 況	×	○	○	○	○	×
総合判断	×	○	○	○	○	×

【0017】以上の結果より、分散粒子径が $10 \sim 500 \mu\text{m}$ であれば固体電解質に割れが発生しないことが判る。

【0018】③ シール材に混入する分散粒子の量が固体電解質の割れに与える影響 (表3)

熱膨張率が $8 \times 10^{-6} / ^\circ\text{C}$ のシール材マトリックス中に

熱膨張率が $4 \times 10^{-6} / ^\circ\text{C}$ で平均粒径が $30 \mu\text{m}$ の SnO_2 を、容量%で3%、5%、10%、20%、40%、60%分散させた。これを図1のシール材6に適用し、上記①と同様な確認試験を行い、その結果を表3に示す。

【表3】

分散粒子量	3	5	10	20	40	60
高温でのシール状況	○	○	○	○	○	×
降温後の状況	固体電解質に割れ	シール材中に割れ	←	←	←	←
再昇温後のシール状況	×	○	○	○	○	×
総合判断	×	○	○	○	○	×

【0019】以上の結果より、分散粒子の分散量が5～40容量%であれば固体電解質に割れが発生しないことが判る。

【0020】

【発明の効果】本発明により固体電解質とシール材の昇温、降温時の熱膨張率の差に基く熱歪による固体電解質

の割れが防止できる固体電解質燃料電池が提供される。

【図面の簡単な説明】

【図1】固体電解質燃料電池の一般的な説明図。

【図2】本発明で使用するシール材の微細組織を示す光学顕微鏡写真。

【図1】

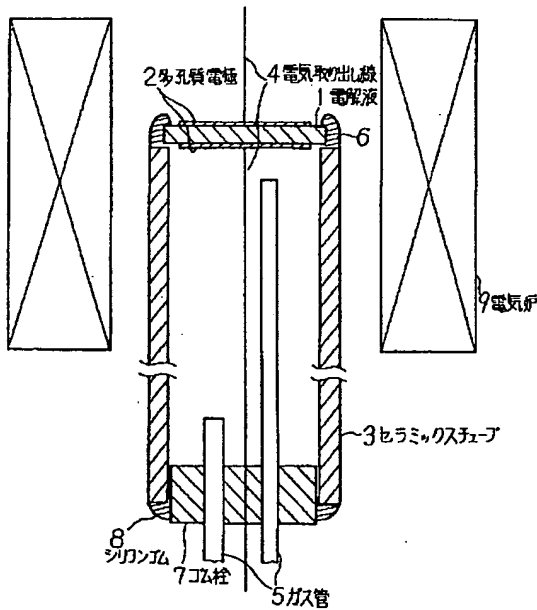

【図2】

